

### CENTURY PSX SERIES BATTERIES

The PSX range are especially designed for heavy load discharge applications with a 5 year design life in float applications. By using strong grids and specially designed active material the PSX series offers stable performance during high current discharge requirements.

The PSX range is also backed with the confidence of a great warranty cover.

- ✓ Design life 5 years
- ✓ 30% more power than standard range
- ✓ Maintenance free

GENERAL							
Application	Float						
Design life	5 years						
Nominal Watts per Cell (wpc)	22 Wpc @ 15 min rate to 1.67VPC @ 25°C						
Actual wpc at 25°C	<table border="1"> <tr> <td>10 Min rate to 1.60Vpc</td> <td>29.8</td> </tr> <tr> <td>15 Min rate to 1.60Vpc</td> <td>23.2</td> </tr> <tr> <td>30 Min rate to 1.60Vpc</td> <td>13.6</td> </tr> </table>	10 Min rate to 1.60Vpc	29.8	15 Min rate to 1.60Vpc	23.2	30 Min rate to 1.60Vpc	13.6
10 Min rate to 1.60Vpc	29.8						
15 Min rate to 1.60Vpc	23.2						
30 Min rate to 1.60Vpc	13.6						

ELECTROLYTE	
Fully charge density at 25°C	1.335
Density Range	1.295-1.305
Gelled/Absorbed	Absorbed
Mounting Orientation	Vertical

PHYSICAL PROPERTIES	
SEPARATOR	
Type	Glass Mat
Is glass fiber included?	Yes
Thickness	0.85 mm
CONTAINER & COVER MATERIALS	
LID Material, Colour	Acrylonitrile Butadiene Styrene ABS/Black
Container Material, Colour	Acrylonitrile Butadiene Styrene ABS/Black
Flame Retardant	No - UL94-HB, Optional UL94-V0
Safety Vent Operational Pressure	20 KPA
DIMENSIONS	
Width	70.0 mm
Length	90.0 mm
Height	101.0 mm
Overall Height	107.0 mm
Battery Weight(kg)	1.65 kg

ELECTRICAL PROPERTIES		
Self Discharge Rate @ 25°C	<3% / mth	
Normal Charge (Amperes)	0.51 A	
Maximum Charge (Amperes)	1.65 A	
Maximum Sustained Current (Without damage discharging 5 Sec)	55 A	
Internal Resistance (mOHMS)	25.0 mΩ	
Float Application	13.7-13.9V per 12V Battery @ 25°C	
Cyclic Application	14.6-14.8 V	
	20°C	25°C
Float Voltage	2.305VPC	2.291VPC
Float Current (mA)	~5.1mA	~5.1mA
Initial Short circuit current (A)	280A	
EFFICIENCY AT 10 HOUR RATE (%)		
Ampere-Hour	>90%	
Watt-Hour	>80%	
Fastener	F2	
COMPLIANT STANDARD		
Manufacturing Standard	IEC 60896-21:2004, IEC 60896-22:2004	

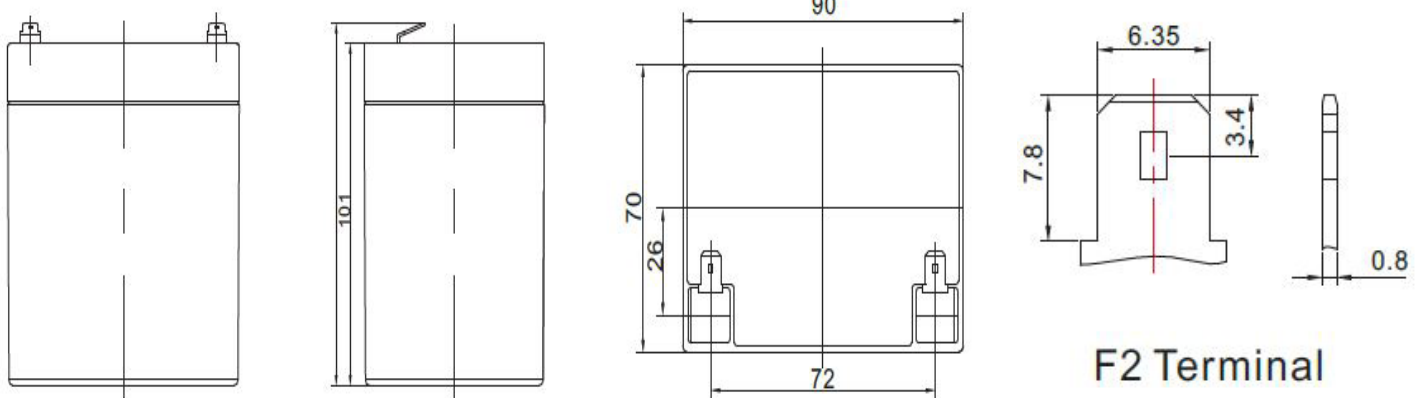

PLATES			
POSITIVE PLATES		NEGATIVE PLATES	
Number/cell	4	Number/cell	5
Type	Flat Pasted	Type	Flat Pasted
Material of grid	Lead - Calcium -Tin Alloy	Type Material of grid	Lead - Calcium -Tin Alloy
Thickness	1.9 mm	Thickness	1.7 mm

CenturyYuasa believes that the data presented is generally accurate for the purpose for which it is presented, however expressly disclaims any representation of warranty expressed or implied, concerning the data or recommendations and in no event shall be liable for any loss or damage claimed to have arisen as a result of the use of this brochure.

### CENTURY PSX SERIES BATTERIES

CONSTANT CURRENT DISCHARGE CHARACTERISTICS: A (25°C)									
FINAL VOLTAGE / TIME	3 MIN	5 MIN	8 MIN	10 MIN	15 MIN	20 MIN	30 MIN	60 MIN	90 MIN
1.60V	25.28	21.98	18.28	16.12	12.47	10.090	7.387	4.308	3.139
1.67V	23.39	20.34	17.14	15.13	11.82	9.412	7.042	4.105	2.989
1.70V	22.42	19.50	16.54	14.58	11.45	9.053	6.843	3.987	2.899
1.75V	21.18	18.41	15.71	13.69	10.91	8.805	6.650	3.922	2.834
1.80V	19.92	17.32	14.89	12.80	10.37	8.544	6.446	3.844	2.765
1.85V	18.59	16.16	14.00	11.87	9.78	8.246	6.208	3.752	2.683

CONSTANT POWER DISCHARGE CHARACTERISTICS: WATTS PER CELL (25°C)									
FINAL VOLTAGE / TIME	3 MIN	5 MIN	8 MIN	10 MIN	15 MIN	20 MIN	30 MIN	60 MIN	90 MIN
1.60V	45.8	39.8	33.6	29.8	23.2	18.5	13.6	8.0	5.8
1.67V	42.8	37.2	31.8	28.2	22.2	17.5	13.1	7.7	5.6
1.70V	41.5	36.1	31.1	27.5	21.8	17.0	12.9	7.5	5.5
1.75V	39.7	34.5	29.9	26.2	21.0	16.7	12.7	7.5	5.4
1.80V	37.9	32.9	28.7	24.8	20.2	16.5	12.5	7.5	5.4
1.85V	36.0	31.3	27.6	23.5	19.5	16.2	12.2	7.4	5.3

All mentioned values are average values (Tolerance  $\pm 2\%$ ).

#### CHARGE CHARACTERISTIC CURVE FOR STANDBY USE

##### Constant Voltage Charge Characteristics

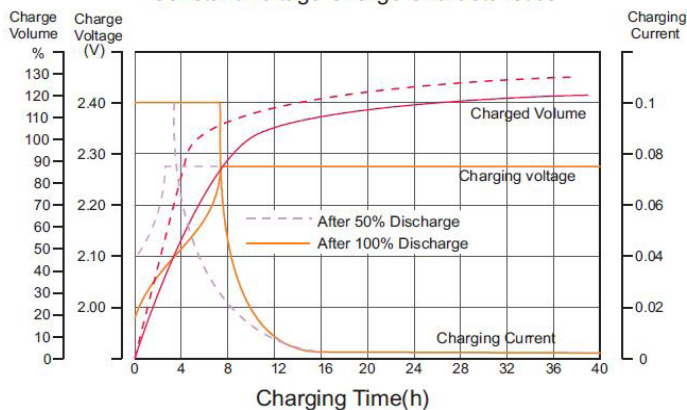

#### DISCHARGE CHARACTERISTIC CURVE

Temperature: 25°C

